

Product data sheet

Specifications



Soft starter, Altistart 480, 790A, 208 to 690V AC, control supply 110 to 230V AC

ATS480C79Y

Product availability: Stock - Normally stocked in distribution facility

Price*: 9,200.99 USD

Main

Range Of Product	Altivar Soft Starter ATS480
Product Or Component Type	Soft starter
Product Destination	Asynchronous motors
Product Specific Application	Process and infrastructures
Device Short Name	ATS480
Phase	3 phase
Utilisation Category	AC-3A AC-53A
Ue Power Supply Voltage	208...690 V - 15...10 %
Power Supply Frequency	50...60 Hz - 20...20 %
[Ie] Rated Operational Current	Normal duty 790.0 A 104 °F (40 °C))
Rated Current In Heavy Duty	660.0 A at 104 °F (40 °C) heavy duty
Torque Control	True
Ip Degree Of Protection	IP00
Motor Power Kw	220.0 kW 230 V in the motor supply line normal duty 400.0 kW 400 V in the motor supply line normal duty 355.0 kW 400 V in the motor supply line heavy duty 500.0 kW 440 V in the motor supply line normal duty 400.0 kW 440 V in the motor supply line heavy duty 500.0 kW 500 V in the motor supply line normal duty 500.0 kW 525 V in the motor supply line normal duty 710.0 kW 660 V in the motor supply line normal duty 630.0 kW 660 V in the motor supply line heavy duty 710.0 kW 690 V in the motor supply line normal duty 630.0 kW 690 V in the motor supply line heavy duty 355.0 kW 230 V to the motor delta terminals normal duty 315.0 kW 230 V to the motor delta terminals heavy duty 630.0 kW 400 V to the motor delta terminals normal duty 500.0 kW 400 V to the motor delta terminals heavy duty
Maximum Horse Power Rating	250.0 hp 208 V normal duty 200.0 hp 208 V heavy duty 300.0 hp 230 V normal duty 250.0 hp 230 V heavy duty 600.0 hp 460 V normal duty 500.0 hp 460 V heavy duty 800.0 hp 575 V normal duty 600.0 hp 575 V heavy duty
Option Card	Communication module Profibus DP V1 Communication module PROFINET Communication module Modbus TCP/EtherNet/IP Communication module CANopen daisy chain Communication module CANopen Sub-D Communication module CANopen open style

Price is "List Price" and may be subject to a trade discount – check with your local distributor or retailer for actual price.

Complementary

Device Connection	In the motor supply line To the motor delta terminals
[Us] Control Circuit Voltage	110...250 V AC 50/60 Hz - 15...10 %
Apparent Power	0.2 kVA
Integrated Motor Overload Protection	True
Motor Thermal Protection Class	Class 10E
Protection Type	Phase failure line Integrated thermal protection motor Thermal protection starter Current overload motor Underload motor Excessive starting time, locked rotor motor Motor phase loss motor Line supply phase loss line Line supply phase loss motor Thermal protection motor
Current Limiting %In (5 X Ie Maximum)	150...700 %
[In] Rated Current Pwr Loss Specifctn	790.0 A
Power Loss Static Current Independent	25.0 W
Power Loss Per Device Current Dependent	2517.0 W
Standards	IEC 60947-4-2 UL 60947-4-2 IEC 60664-1
Product Certifications	CE cULus CCC UKCA RCM EAC DNV ABS BV CCS
Marking	CE CCC UKCA EAC RCM CULus
[Uc] Control Circuit Voltage	24 V DC
Discrete Input Number	4
Discrete Input Type	STOP) logic inputs, 3500 Ohm RUN) logic inputs, 3500 Ohm DI3) programmable as logic input, 3500 Ohm DI4) programmable as logic input, 3500 Ohm
Input Compatibility	STOP discrete input level 1 PLC IEC 61131-2 RUN discrete input level 1 PLC IEC 61131-2 DI3 discrete input level 1 PLC IEC 61131-2 DI4 discrete input level 1 PLC IEC 61131-2
Discrete Input Logic	Programmable digital input < 5 V
Relay Output Number	3
Relay Output Type	Relay outputs R1A 1 NO Relay outputs R1B 1 NO Relay outputs RIC NO/NC programmable
Minimum Switching Current	100 mA 12 V DC relay outputs

Maximum Switching Current	Relay outputs 2 A 250 V AC Relay outputs 2 A 30 V DC Relay outputs
Discrete Output Number	2
Discrete Output Type	DQ1) programmable digital output <= 30 V DQ2) programmable digital output <= 30 V
Output Compatibility	Open collector level 1 PLC IEC 65A-68
Analogue Input Number	1
Analogue Input Type	A11/PTC PTC/Pt 100 temperature probe PTC2 PTC/Pt 100 temperature probe PTC3 PTC/Pt 100 temperature probe
Analogue Output Number	1
Analogue Output Type	Current output AQ1 0...20 mA or 0...10 V 500 Ohm
Communication Port Protocol	Modbus serial
Connector Type	1 RJ45
Communication Data Link	Serial
Physical Interface	2-wire RS 485
Transmission Rate	1200...256000 bit/s
Transmission Frame	RTU
Data Format	8 bits, configurable odd, even or no parity
Type Of Polarization	No impedance Modbus serial
Number Of Addresses	0...227 Modbus serial
Method Of Access	Slave Modbus serial
Function Available	External bypass control Pre-heating Smoke extraction Multi-motor cascade Second motor set User management Ports and services hardening Security event logging Cybersecure firmware update Single direction
Display Screen Available	True
Operating Position	Vertical +/- 10 degree
Height	35.04 in (890.0 mm)
Width	30.31 in (770.0 mm)
Depth	12.95 in (329.0 mm)
Net Weight	253.53 lb(US) (115.0 kg)

Environment

Electromagnetic Compatibility	Conducted and radiated emissions level A IEC 60947-4-2 Conducted and radiated emissions with bypass level B IEC 60947-4-2 Damped oscillating waves level 3 IEC 61000-4-12 Electrostatic discharge level 3 IEC 61000-4-11 Immunity to electrical transients level 4 IEC 61000-4-4 Immunity to radiated radio-electrical interference level 3 IEC 61000-4-3 Voltage/current impulse level 3 IEC 61000-4-5
Pollution Degree	Level 3
[Uimp] Rated Impulse Withstand Voltage	6 kV

[Ui] Rated Insulation Voltage	690 V
Environmental Class (During Operation)	Class 3C3 according to IEC 60721-3-3 Class 3S2 according to IEC 60721-3-3
Relative Humidity	0...95 % without condensation or dripping water IEC 60068-2-3
Ambient Air Temperature For Operation	104...140 °F (40...60 °C) with current derating of 2 % per °C) 5...104 °F (-15...40 °C) without derating)
Ambient Air Temperature For Storage	-13...158 °F (-25...70 °C)
Operating Altitude	<= 3280.84 ft (1000 m) without derating > 3280.84...13123.36 ft (> 1000...4000 m) with current derating 1 % per 100 m
Maximum Deflection Under Vibratory Load (During Operation)	1.5 mm at 2...13 Hz
Maximum Deflection Under Vibratory Load (During Storage)	1.75 mm at 2...9 Hz
Maximum Deflection Under Vibratory Load (During Transport)	1.75 mm at 2...9 Hz
Maximum Acceleration Under Vibrational Stress (During Operation)	10 m/s ² at 13...200 Hz
Maximum Acceleration Under Vibratory Load (During Storage)	15 m/s ² at 200...500 Hz 10 m/s ² at 9...200 Hz
Maximum Acceleration Under Vibratory Load (During Transport)	15 m/s ² at 200...500 Hz 10 m/s ² at 9...200 Hz
Maximum Acceleration Under Shock Impact (During Operation)	150 m/s ² at 11 ms
Maximum Acceleration Under Shock Load (During Storage)	100 m/s ² at 11 ms
Maximum Acceleration Under Shock Load (During Transport)	100 m/s ² at 11 ms

Ordering and shipping details

Category	22588-OPEN ATS480 ALTISTART
Discount Schedule	CP1G
Gtin	3606481089175
Returnability	Yes

Packing Units

Unit Type Of Package 1	PCE
Number Of Units In Package 1	1
Package 1 Height	23.23 in (59.0 cm)
Package 1 Width	37.40 in (95.0 cm)
Package 1 Length	40.55 in (103.0 cm)
Package 1 Weight	297.62 lb(US) (135.0 kg)

Sustainability

Green Premium™ label is Schneider Electric's commitment to delivering products with best-in-class environmental performance. Green Premium promises compliance with the latest regulations, transparency on environmental impacts, as well as circular and low-CO₂ products.

Guide to assessing product sustainability is a white paper that clarifies global eco-label standards and how to interpret environmental declarations.

[Learn more about Green Premium >](#)

[Guide to assess a product's sustainability >](#)



Transparency RoHS/REACH

Resource performance

 Upgraded Components Available

Well-being performance

 Mercury Free

 Rohs Exemption Information Yes

Certifications & Standards

Reach Regulation

[REACH Declaration](#)

Eu Rohs Directive

Pro-active compliance (Product out of EU RoHS legal scope)

China Rohs Regulation

[China RoHS declaration](#)

Environmental Disclosure

[Product Environmental Profile](#)

Weee

The product must be disposed on European Union markets following specific waste collection and never end up in rubbish bins.

Circularity Profile

[End of Life Information](#)

California Proposition 65

WARNING: This product can expose you to chemicals including: Lead and lead compounds, which is known to the State of California to cause cancer and birth defects or other reproductive harm. For more information go to www.P65Warnings.ca.gov

Dimensions

Front, Side and Rear View

mm
in.

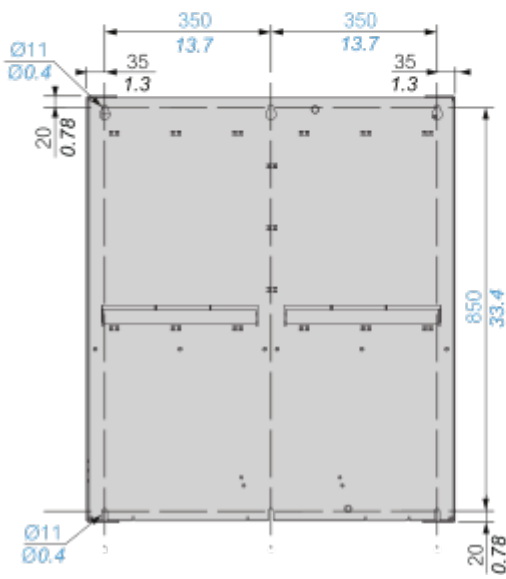
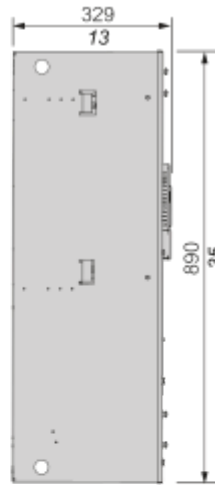
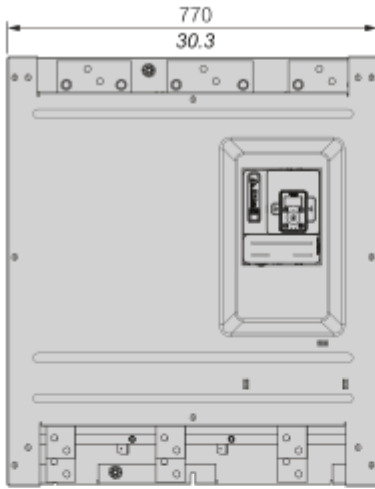

Power Connections

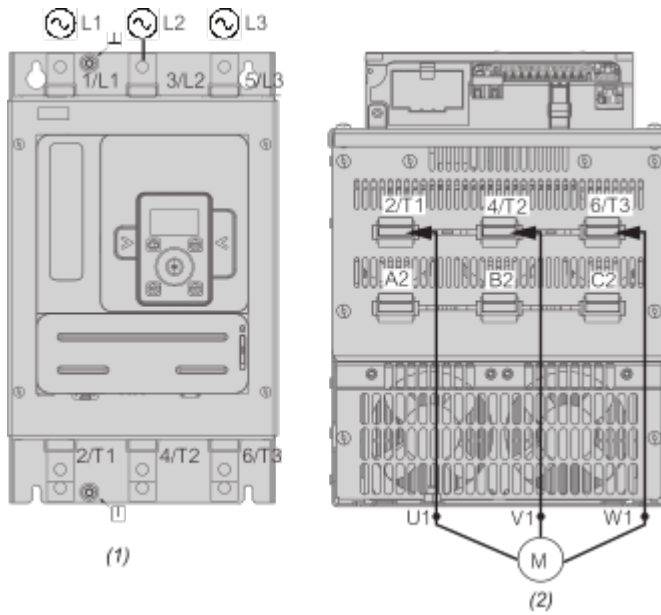

(1) : Mains side

(2) : Motor side

1/L1, 3/L2, 5/L3 : Mains supply inputs

2/T1, 4/T2, 6/T3 : Outputs to motor

A2, B2, C2 : Soft starter bypass

Connection in line, with line contactor, no bypass, type 1 or 2 coordination, non-reversing, 2-wire or 3-wire control

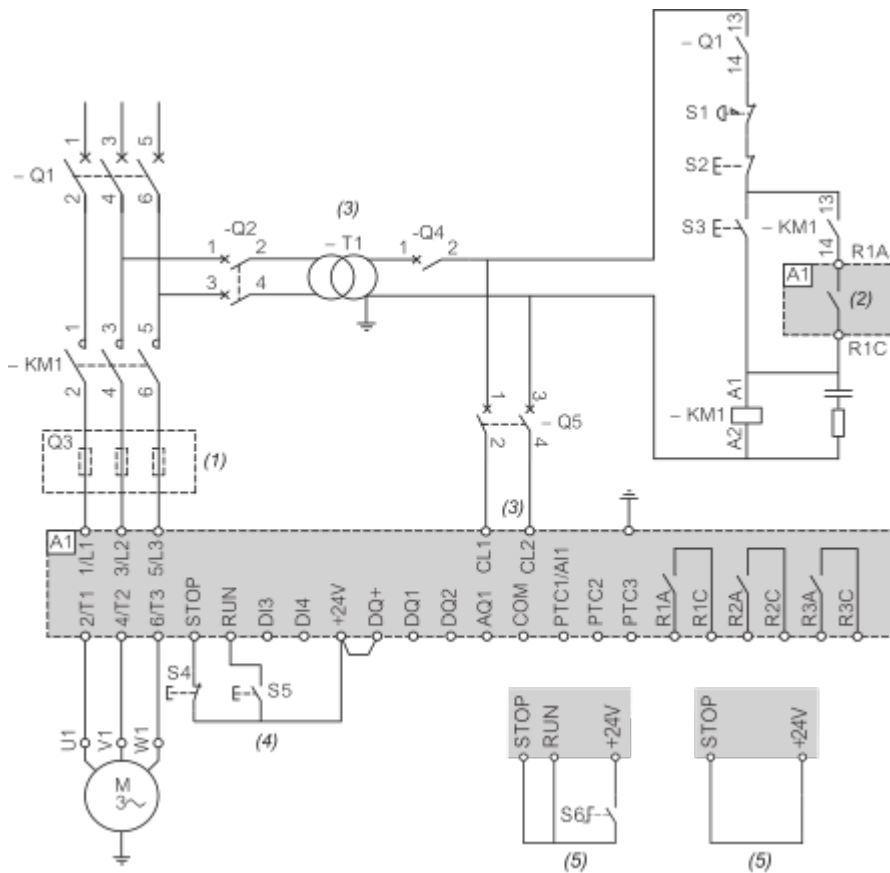

- (1) : Installation of additional fast-acting fuses to upgrade to type 2 coordination according to IEC 60947-4-2.
- (2) : Take into account the electrical characteristics of the relays (Control Terminal Characteristics).
- (3) : The transformer must supply 110...230 VAC +10% — 15%, 50/60Hz.
- (4) : RUN and STOP Management (3-wire control).
- (5) : RUN and STOP Management (2-wire control).

Connection in line, with line and bypass contactor, freewheel or controlled stop, type 1 or 2 coordination, non reversing, 2-wire or 3-wire

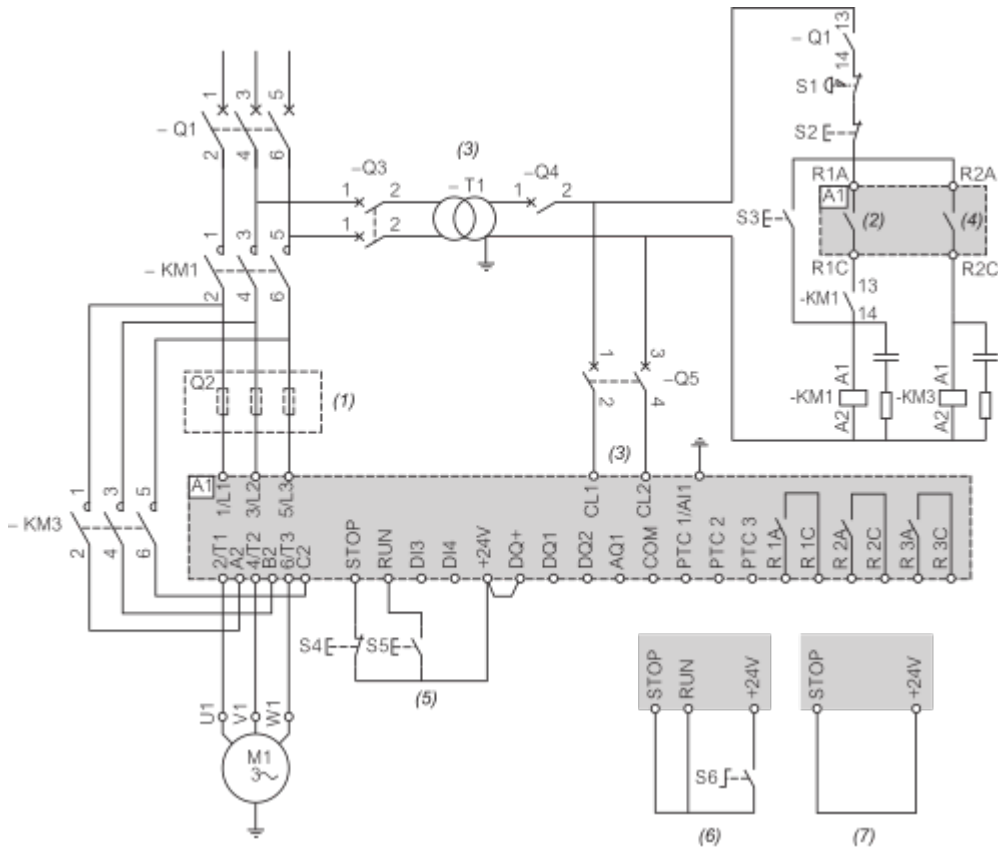

- (1) : Installation of additional fast-acting fuses to upgrade to type 2 coordination according to IEC 60947-4-2.
- (2) : Take into account the electrical characteristics of the relays (Control Terminal Characteristics).
- (3) : The transformer must supply 110...230 VAC +10% - 15%, 50/60Hz.
- (4) : Take into account the electrical characteristics of the relays, especially when connecting to high rating contactor (Control Terminal Characteristics).
- (5) : RUN and STOP Management (3-wire control).
- (6) : RUN and STOP Management (2-wire control).
- (7) : PC or PLC control

Connection inside the delta, with line and bypass contactor, type 1 and 2 coordination, non reversing, 2 wire or 3 wire

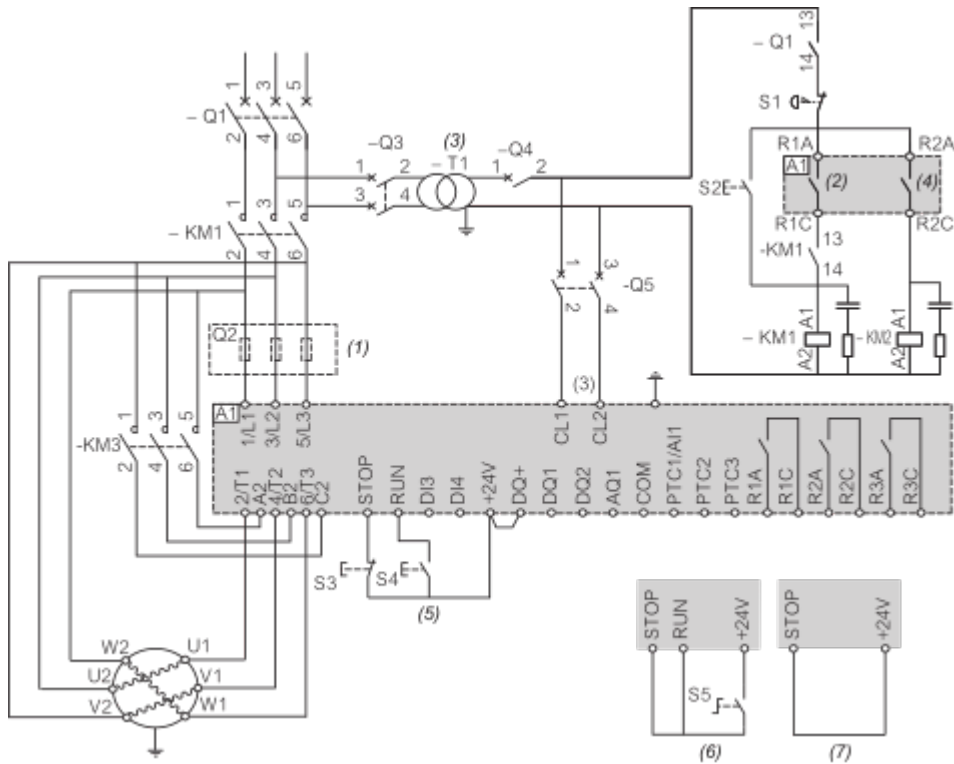

- (1) : Installation of additional fast-acting fuses to upgrade to type 2 coordination according to IEC 60947-4-2.
- (2) : Take into account the electrical characteristics of the relays (Control Terminal Characteristics).
- (3) : The transformer must supply 110...230 VAC +10% – 15%, 50/60Hz.
- (4) : Take into account the electrical characteristics of the relays, especially when connecting to high rating contactor (Control Terminal Characteristics).
- (5) : RUN and STOP Management (3-wire control).
- (6) : RUN and STOP Management (2-wire control).
- (7) : PC or PLC control

Control block wiring diagram

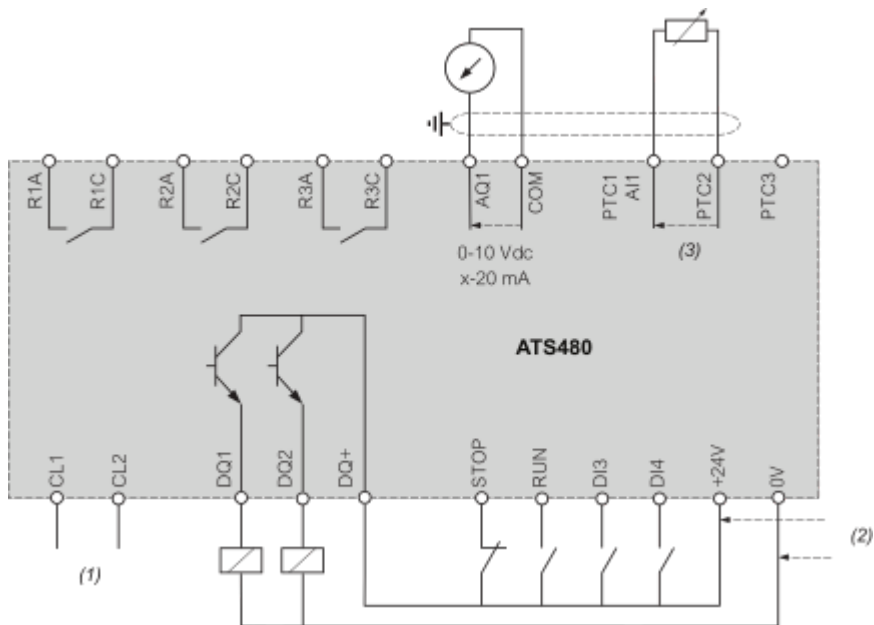

(1) : Control power supply 110-230 VAC

(2) : External supply 24 VDC

(3) : 2 Wires PTC/PT100

R1A, R1C, R3A, R3C : Sequence relay

R2A, R2C : End of start

STOP, RUN, DI3, DI4 : Digital inputs

AQ1 : Analogue output

PTC1/AI1, PTC2, PTC3 : PTC or PT100 connection

DQ1, DQ2, DQ+ : Digital outputs

Mounting Position

mm
in.

